

SIN 246 / SIN 346

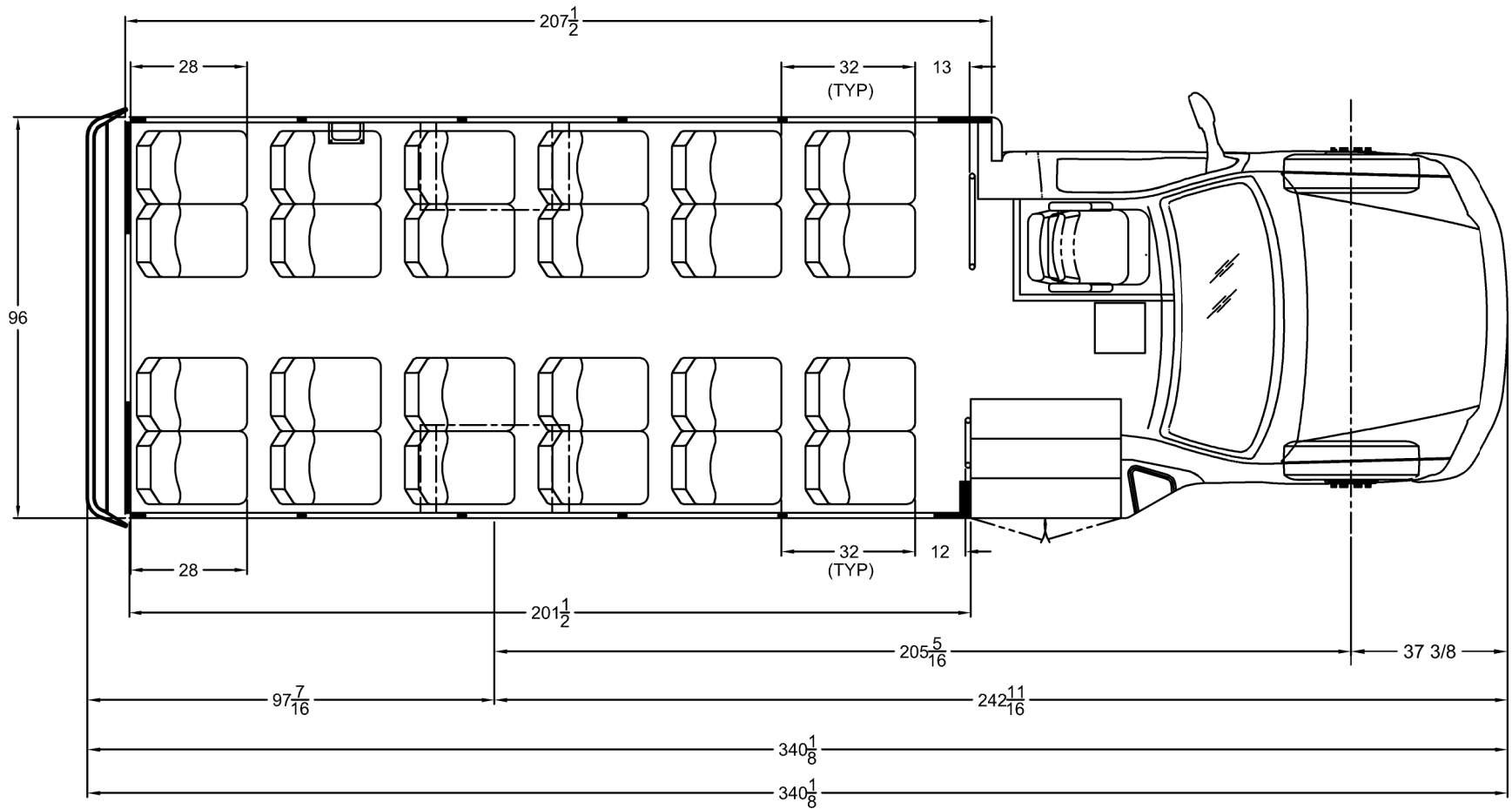

NOTE: SHOWN WITH MID HI FREEDMAN SEATS  
 SENATOR HD F-450 16,500 GVWR  
 THIS FLOOR PLAN IS FOR ILLUSTRATION PURPOSES ONLY.  
 A WEIGHT ANALYSIS HAS NOT YET BEEN PERFORMED.  
 FINAL APPROVAL WITH A WEIGHT ANALYSIS IS REQUIRED UPON RECEIPT OF A  
 COMPLETED ORDER WITH ALL OPTIONS SHOWN.  
 OPTIONAL EQUIPMENT MAY BE SHOWN.  
 THE SALES ORDER PLACED DICTATES ACTUAL OPTION CONTENT.

DEALER APPROVAL

APPROVED

\_\_\_\_\_  
 CUSTOMER SIGNATURE

SCALE  
 IN INCHES

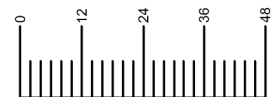

THIS DRAWING AND THE INFORMATION THEREON ARE THE EXCLUSIVE PROPERTY OF STARTRANS BUS, A DIVISION OF FOREST RIVER. IT SHALL NOT BE COPIED OR DUPLICATED IN ANY MANNER, NOR SHALL IT BE SUBMITTED TO OUTSIDE PARTIES FOR EXAMINATION WITHOUT OUR WRITTEN CONSENT. IT IS LOANED FOR USE WITH REFERENCE TO WORK UNDER CONTRACT WITH, OR PROPOSALS SUBMITTED TO STARTRANS BUS, A DIVISION OF FOREST RIVER.

REV. LET.	DESCRIPTION OF CHANGE	BY	CHK	DATE	ECN No.

TOLERANCE UNLESS OTHERWISE SPECIFIED		 <b>STARTRANS</b> a division of Forest River, Inc.	
WOOD	OTHER	DATE: 02/20/17	TITLE: 24 PASSENGER 205" WB 201 BDY
± 1/8"	± 1/16"	NAME: JPC	28' SENATOR HD
± 1°	± 1/2°	DWG. No.	24 PASSENGER 205 WB 201 BDY