

SIN 247 / SIN 347

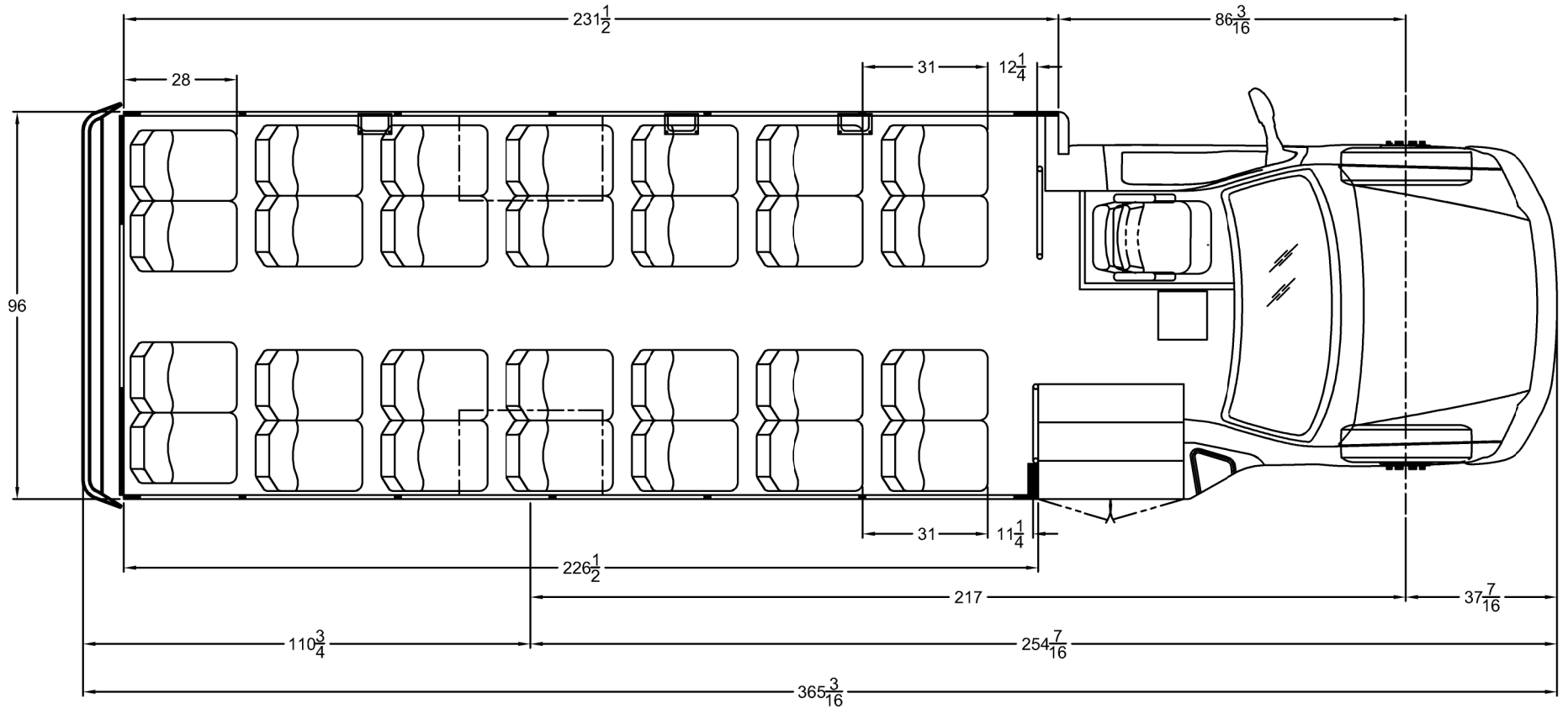

DEALER APPROVAL

APPROVED

CUSTOMER SIGNATURE

NOTE: SHOWN WITH MID HI FREEDMAN SEATS
 SENATOR HD F-550 19,500 GVWR
 THIS FLOOR PLAN IS FOR ILLUSTRATION PURPOSES ONLY.
 A WEIGHT ANALYSIS HAS NOT YET BEEN PERFORMED.
 FINAL APPROVAL WITH A WEIGHT ANALYSIS IS REQUIRED UPON RECEIPT OF A
 COMPLETED ORDER WITH ALL OPTIONS SHOWN.
 OPTIONAL EQUIPMENT MAY BE SHOWN.
 THE SALES ORDER PLACED DICTATES ACTUAL OPTION CONTENT.

SCALE
 IN INCHES

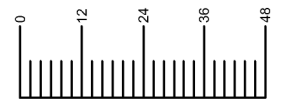

THIS DRAWING AND THE INFORMATION THEREON ARE THE EXCLUSIVE PROPERTY OF STARTRANS BUS, A DIVISION OF FOREST RIVER. IT SHALL NOT BE COPIED OR DUPLICATED IN ANY MANNER, NOR SHALL IT BE SUBMITTED TO OUTSIDE PARTIES FOR EXAMINATION WITHOUT OUR WRITTEN CONSENT. IT IS LOANED FOR USE WITH REFERENCE TO WORK UNDER CONTRACT WITH, OR PROPOSALS SUBMITTED TO STARTRANS BUS, A DIVISION OF FOREST RIVER.

REV. LET.	DESCRIPTION OF CHANGE	BY	CHK	DATE	ECN No.

TOLERANCE UNLESS OTHERWISE SPECIFIED		 STARTRANS a division of Forest River, Inc.	
WOOD	OTHER	DATE: 02/17/17	TITLE: 28 PASS 217" WB 226 BDY 30' SENATOR HD
± 1/8"	± 1/16"	NAME: JPC	DWG. No. 28 PASS 217 226 USA
± 1°	± 1/2°		